

# MITIGATION OF GPS VULNERABILITY

## USING TIME TRANSFER OVER MICROWAVE SYSTEMS

ITSF NOVEMBER 2013

Anurag Gupta  
Aviat Networks, Inc.

# Abstract

---

This presentation enumerates the critical infrastructure sectors that use GPS for Frequency or Time and are connected over one or more microwave links.

It touches up on how each of the sectors are likely to use the time/frequency

The mechanisms of transferring frequency and time over microwave links are covered and possible methods of backing up GPS are suggested

The level of accuracy in frequency/time transfer required for the backup mechanisms for some of the CIS sectors is also proposed.

# Critical Infrastructure Sectors

## Critical Infrastructure Sectors

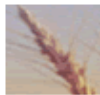

[Agriculture and Food](#)



[Banking and Finance](#)



[Chemical](#)



[Commercial Facilities](#)



[Communications](#)



[Critical Manufacturing](#)



[Dams](#)



[Defense Industrial Base](#)



[Emergency Services](#)



[Energy](#)



[Government Facilities](#)



[Healthcare and Public Health](#)



[Information Technology](#)



[National Monuments and Icons](#)



[Nuclear Reactors, Materials and Waste](#)



[Postal and Shipping](#)



[Transportation Systems](#)



[Water](#)

List of the Critical Infrastructure sectors from about 2 years ago.

Recent visit to the DHS web site shows two sectors removed from the list

- Postal and Shipping
- National Monuments & Icons

[http://www.dhs.gov/files/programs/gc\\_1189168948944.shtm](http://www.dhs.gov/files/programs/gc_1189168948944.shtm)

# Critical Infrastructure Sectors

Critical Infrastructure Sector	GPS for frequency/ time	Microwave Connectivity
Banking & Finance	Time	yes
Chemical	Time	yes
Commercial Facilities	?	?
Communications	Time/ frequency	Mostly Yes
Critical Manufacturing	Time	yes
Dams	Time/ frequency	yes
Defense Industrial Base	Time	? (yes)
Emergency Services	Time	Yes
Energy	Time/ frequency	Yes
Food & Agriculture	x	x
Government Facilities	Time (?)	Yes/ May be
Healthcare & Public Health	x	Yes
Information Technology	Time/ Frequency	Yes
Nuclear Reactors, Materials & Waste	Time	Yes
Transportation	Time/ Geospatial apps	?
Water	(?)	Yes

Number of CIS that depend on GPS for  
Time or frequency **10**

Number of CIS that have microwave  
connectivity **12**

Overlap **100%**

Microwave can effectively provide coverage  
for

Back up to GPS for time/ frequency

# Typical Uses of Time/ Frequency

---

## Communications

Applicable Sectors: Telecom, IT, Emergency Services

- Synchronization of Networks- TOD, Phase, frequency
- Handing over of calls between adjacent communicating entities

## SCADA- Supervisory, Control & Data Acquisition

Applicable Sectors: Chemical, Critical Manufacturing, Dams ,Defense Industrial Base, Energy, Nuclear Reactors.

- Providing common time base for supervisory, control & alarm events
- Support for event logging

## PMU synchronization

Applicable Sectors: Energy, Nuclear (power generation)

## Regulatory Compliance, Transactional Forensics

Applicable Sectors: Finance, Banking

- Transaction logging

These are some conditions unique to  $\mu$ Wave deployments

1. Links are essentially line of sight (LOS)
2. Due to varying environmental conditions the adaptive modulation techniques are used
3. Irrespective of modulation used the framing used by each manufacturer's equipment is unique
4. This implies that the  $\mu$ Wave link is book-ended by equipment from same manufacturer.

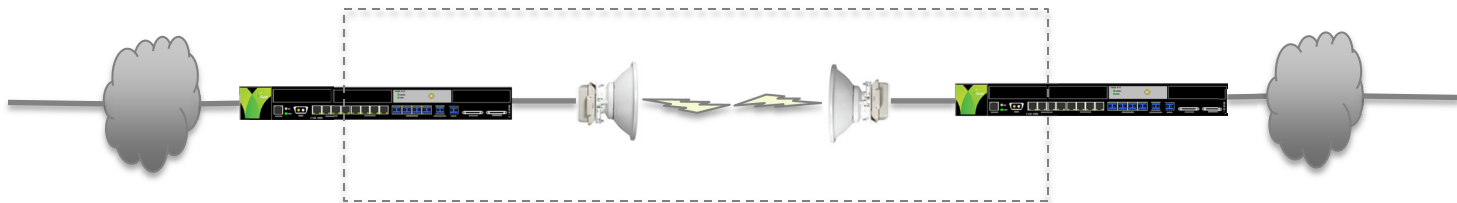

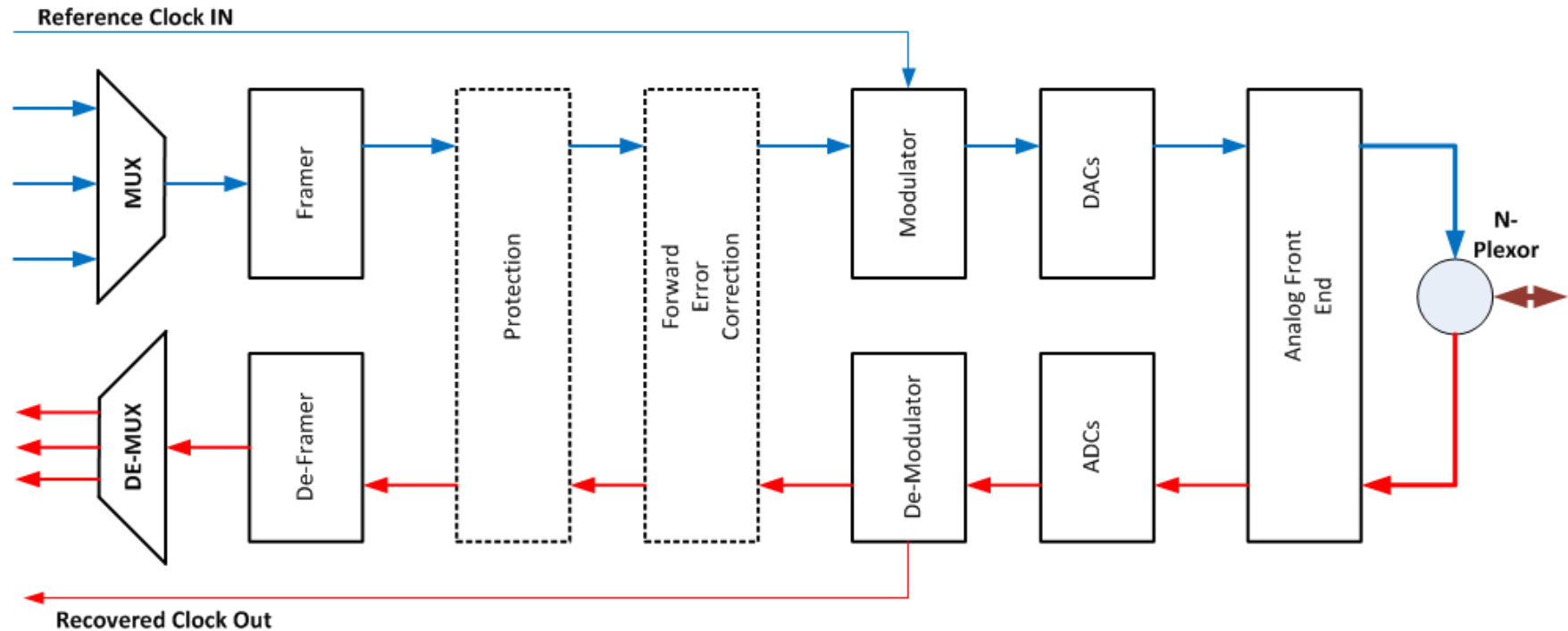

- Data passes through a Framer, Protection mechanisms, FEC , Digital modems & AFE
- Reverse on the way back

# Time transfer over microwave links

## Step 1- Transferring frequency

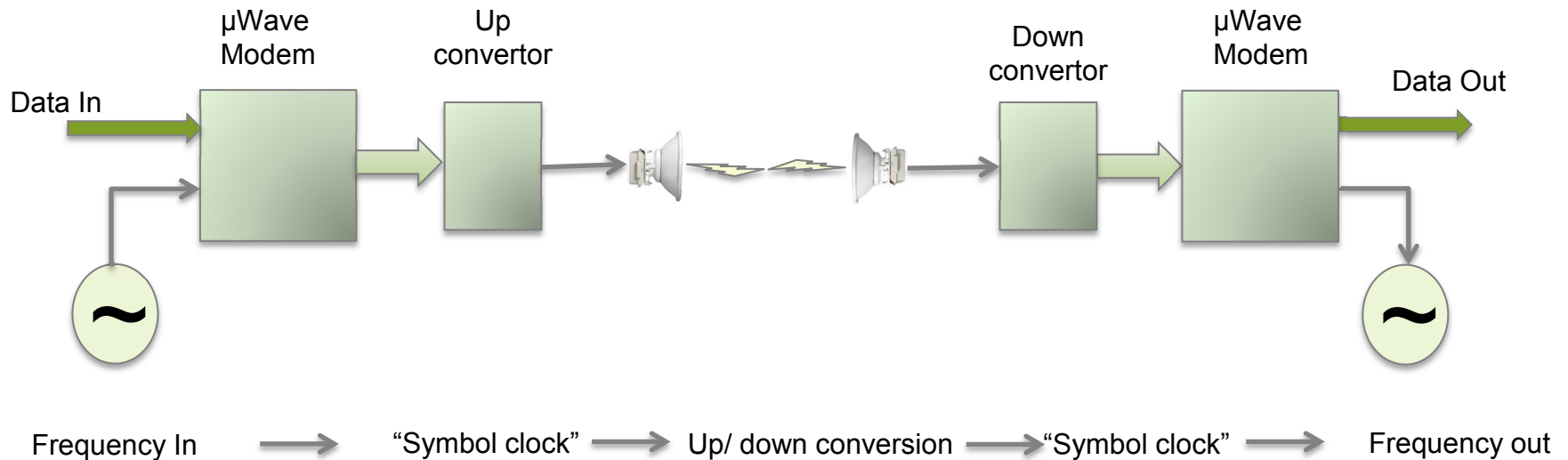

- The Frequency Out is physically traceable to Frequency In
  - $F_{in}$  is used to generate the "symbol" at the transmit end.
  - Symbol clock is recovered by the modem at the receive end
  - $F_{out}$  is regenerated from the symbol clock
- This scenario is reminiscent of the Sync-E operation

Step 2 option A - Transferring Phase "A relatively simplistic way"

Run PTP/ IEEE 1588 over the microwave link

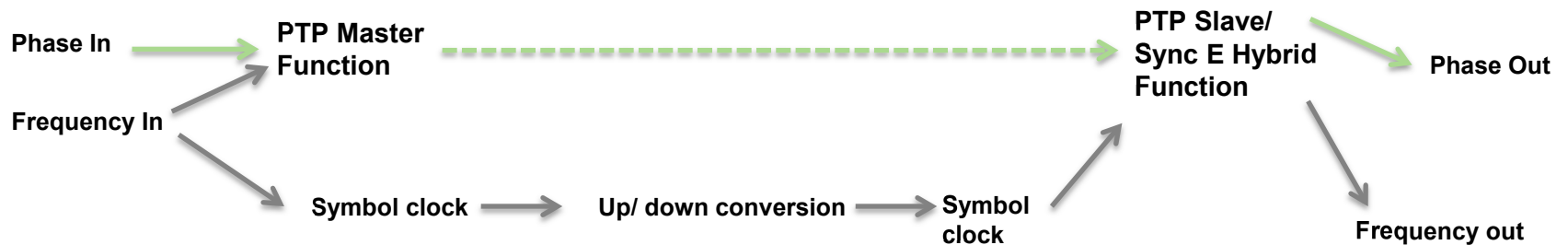
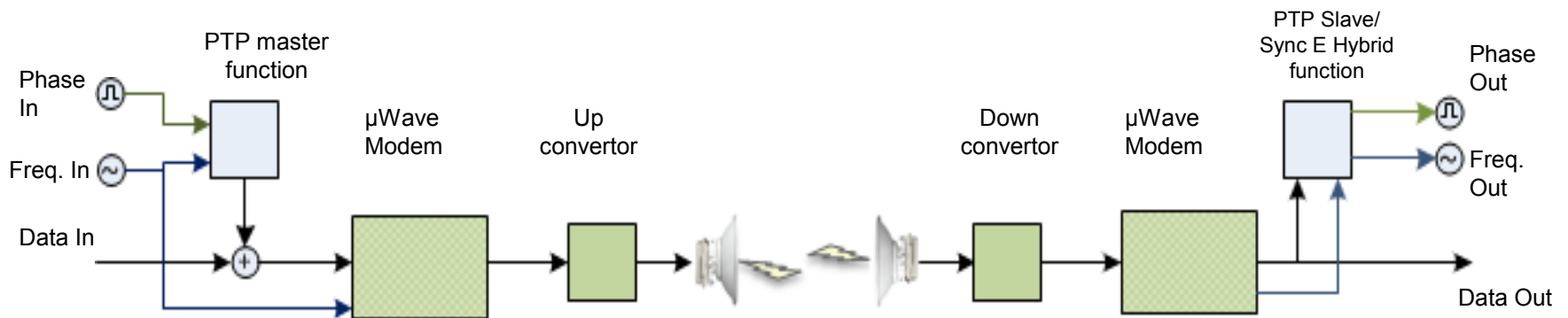

## Step 2 option A - Transferring Phase “A relatively simplistic way”

- On the upstream node common frequency ( $F_{in}$ ) is fed to the Physical layer and PTP function.
- The “Phase<sub>in</sub>“
  - Is fed to the PTP master function
  - Is transferred in-band over the packet data path
  - Recovered at the remote end by PTP “slave” function
- The output phase and frequency are aligned using techniques similar to those used in PTP- Sync-E Hybrid modes

Pro(s)	Con(s)
Needs no special support from modem, IF or RF functions	Requires relatively complex hardware and software implementations
	To achieve accurate phase recovery the PTP servo function would need to be ACM state aware
	Cost

# Step 2 option B- Transferring Phase- I/F stage support

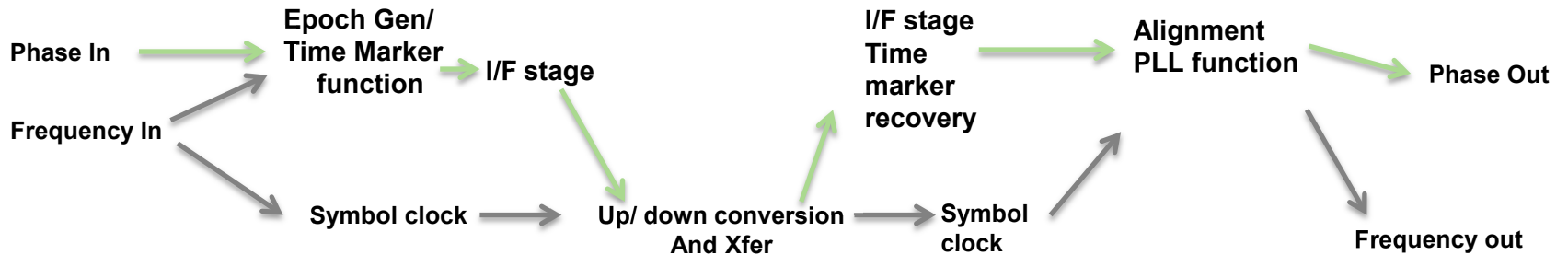
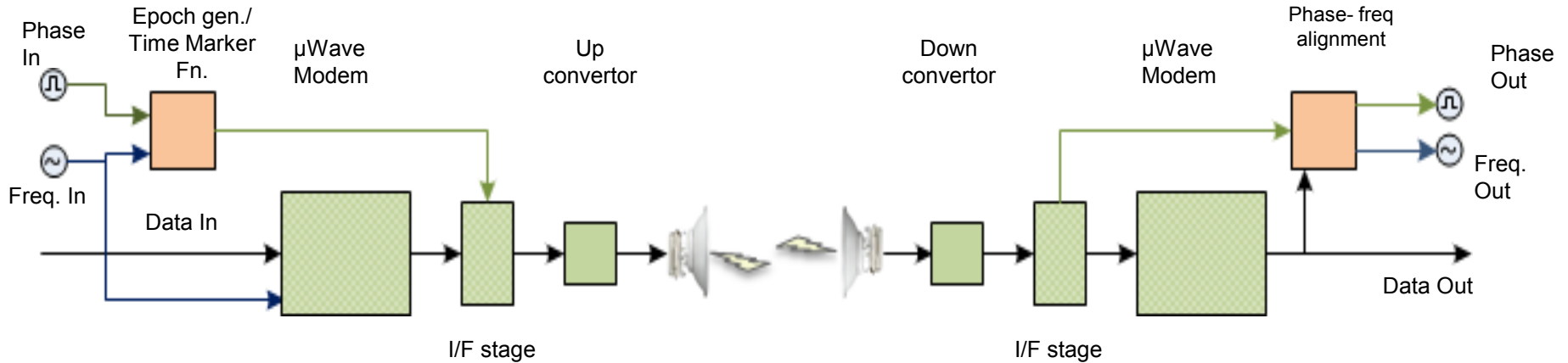

## Step 2 option B- Transferring Phase- I/F stage support

- On the upstream node common frequency ( $F_{in}$ ) is fed to the Physical layer and Time marker/ epoch generation function.
- The  $Phase_{in}$ 
  - is fed to the (above) time marker function
  - The time marker is used to generate “time marker” event at the I/F stage
  - The event is Recovered at the remote I/F stage
- The output phase and frequency are aligned using standard DPLL techniques.

Pro(s)	Con(s)
Cost would be lower than option A	Requires Time marker event generation and recovery support at the I/F stage in microwave modems
Relatively straight forward logic implementable in simple CPLD/ FPGA	

# Step 2 option C- Transferring Phase- modem support

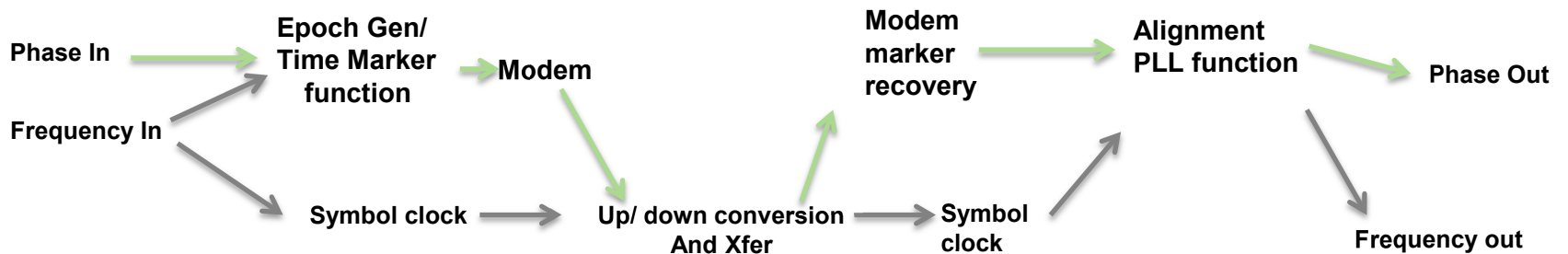
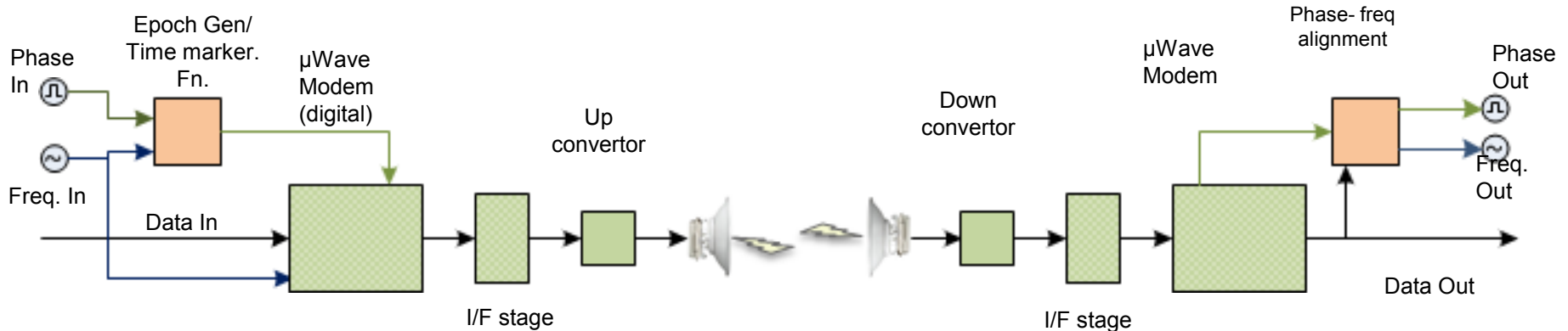

## Step 2 option C- Transferring Phase- modem support

- On the upstream node common frequency ( $F_{in}$ ) is fed to the Physical layer and Time marker/ epoch generation function.
- The  $Phase_{in}$ 
  - Is fed to the (above) time marker function
  - This is used to generate “time marker” event at the “Modem” stage on the Tx side
  - The event is recovered at the remote modem
- The output phase and frequency are aligned using standard DPLL techniques.

Pro(s)	Con(s)
Cost would be lower than option B	Requires Time marker event generation and recovery support at the stage in microwave modems
Relatively straight forward logic implementable in simple CPLD/ FPGA	

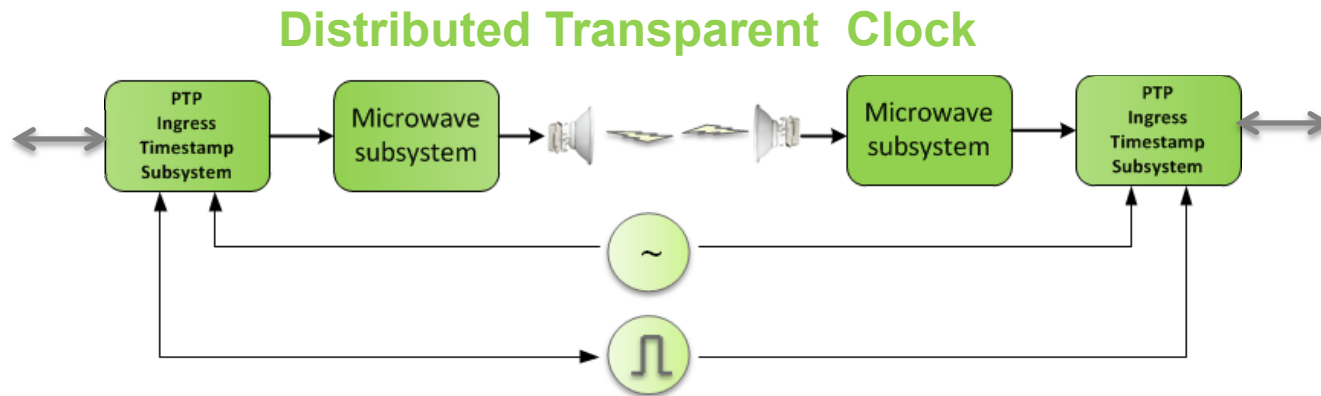
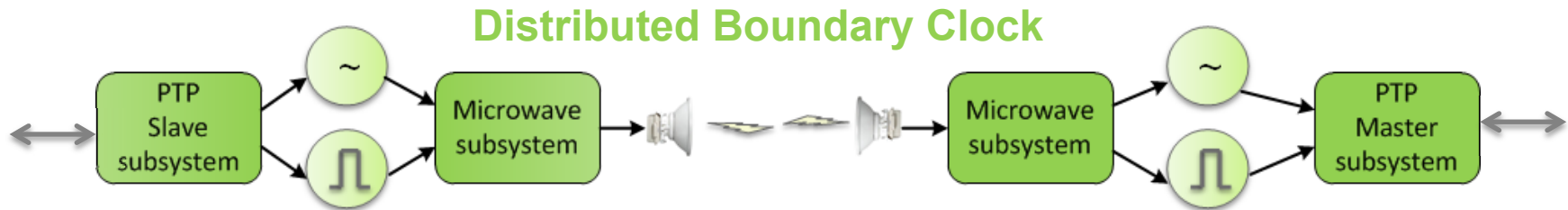
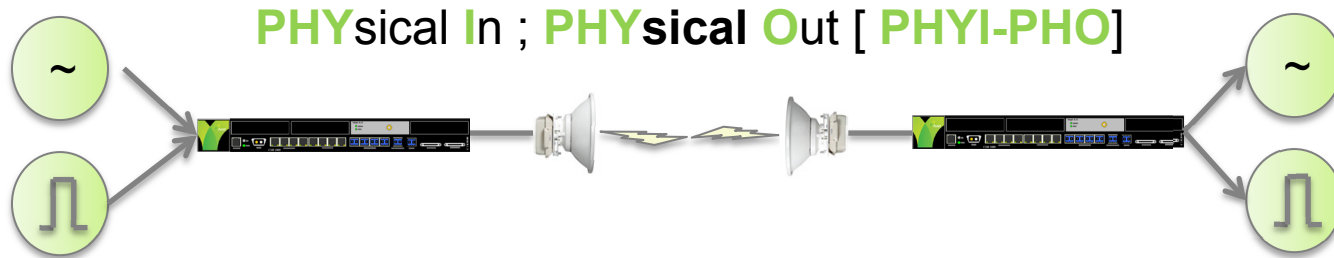

# Mitigation

## Geographic Diversity & Redundancy

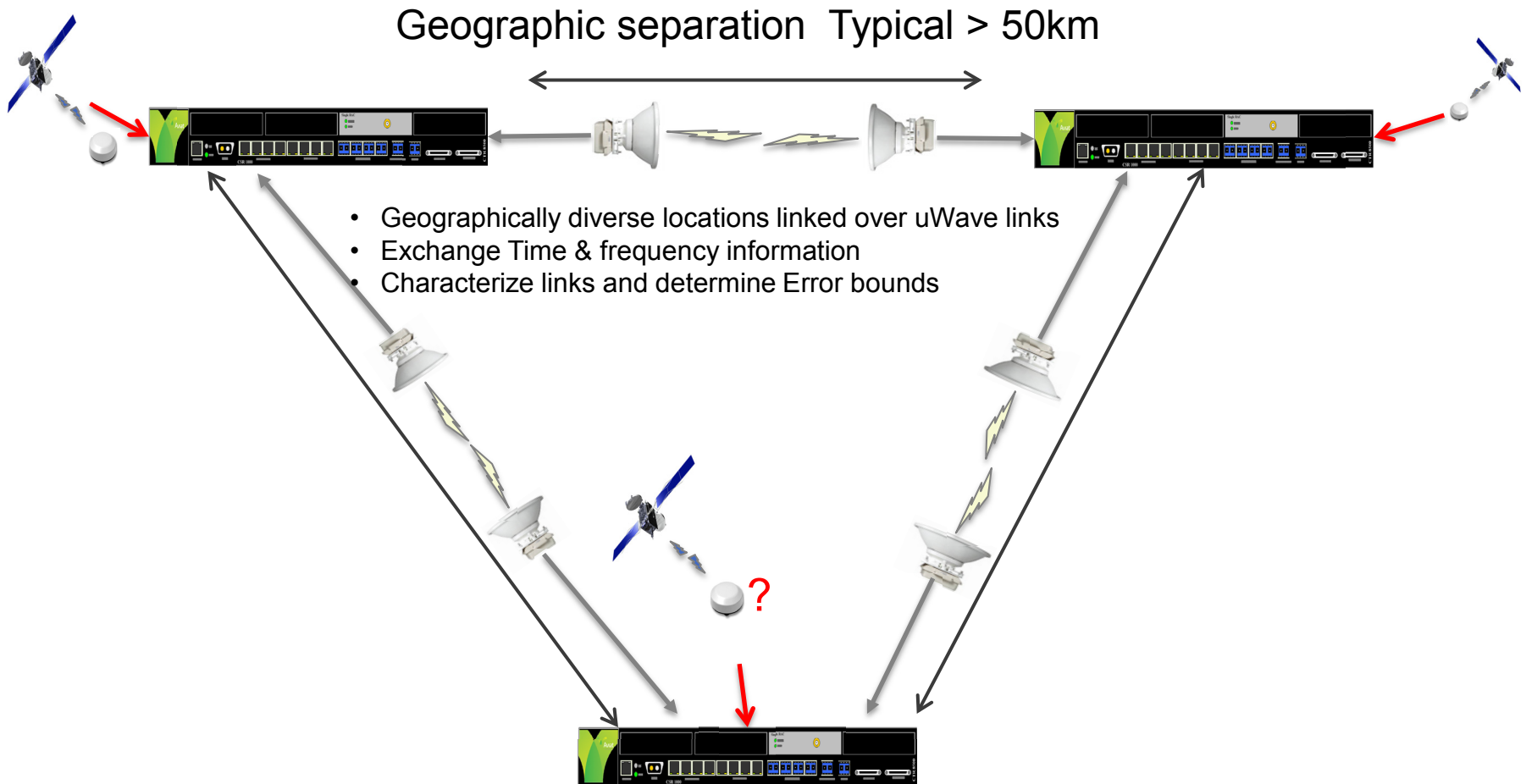

If GPS is compromised, the system could switch over to the uWave Backup

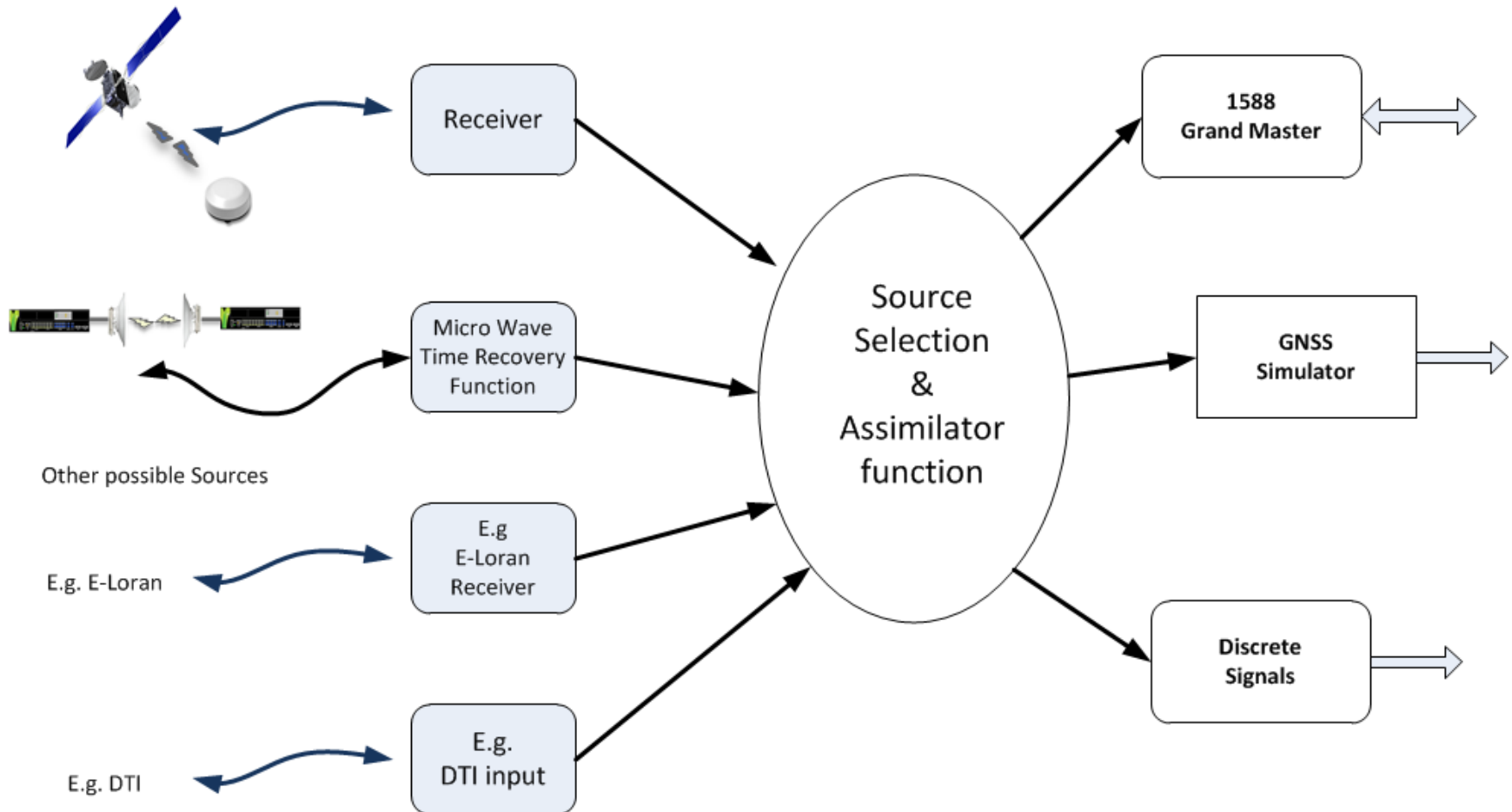

## Targeted Accuracy

## By Application

This table proposes targets for time/ frequency accuracy by applications

CIS/ Application	End application accuracy target	Clock accuracy ( lines in the sand 😊)
Telecom ( aggregation)	500ns to 1.5uS	~50 nS
Telecom ( leaf nodes)	> 1 uS	~50 nS
Energy / Power PMU	1uS to 10uS	50nS
Multiple / fault logging	10uS to 5mS	100 -500 nS
Multiple / SCADA	<1ms to 100mS	100 -500 nS
HTF/ Latency Measurements	500uS to 10mS	100 -500 nS
Finance/ Transactional TS	10 to 100mS	100 -500 nS

Open invitation to audience to augment the table....

## Summary & Conclusion

---

- Most entities in CIS use GNSS for synchronization  
.....use Microwave for communication
- Microwave links with timing enhancements  
.....can provide reliable back up to GPS for synchronization applications

THANK YOU FOR YOUR ATTENTION.....

QUESTIONS?

Anurag Gupta

+1-408-567-7286

Email: [anurag.gupta@aviatnet.com](mailto:anurag.gupta@aviatnet.com)